

**PALLONI RIANIMATORI IN SILICONE - Con impugnatura**  
**SILICONE AUTOCLAVABLE RESUSCITATORS - With handle**  
**RÉANIMATEURS AUTOCLAVABLES EN SILICONE - Avec poignée**  
**RESUCITADORES DE SILICONA AUTOCLAVABLES - Con mango**  
**RESSUSCITADORES AUTOCLAVÁVEIS EM SILICONE - Com pega**  
**RESUSCITATOARE AUTOCLAVABILE DIN SILICON - Cu mâner**  
**ΣΥΣΚΕΥΕΣ ΑΝΑΖΩΟΓΟΝΗΣΗΣ ΣΙΛΙΚΟΝΗΣ ΣΕ ΑΥΤΟΚΛΕΙΣΤΟ - Με λαβή**  
**AUTOKLAVERINGSBARA ÅTERUPPVÄNDNINGSMATERIALER I SILIKON**  
**- Med handtag**

Manuale d'uso - User manual - Manuel de l'utilisateur - Manual de uso y mantenimiento - Manual de uso e manutenção - Manual de utilizare și întreținere- Εγχειρίδιο χρήσης και συντηρησης - Instruktioner för användning och underhåll

**ATTENZIONE:** Gli operatori devono leggere e capire completamente questo manuale prima di utilizzare il prodotto.

**ATTENTION:** The operators must carefully read and completely understand the present manual before using the product.

**AVIS:** Les opérateurs doivent lire et bien comprendre ce manuel avant d'utiliser le produit.

**ATENCIÓN:** Los operadores tienen que leer y entender completamente este manual antes de utilizar el producto.

**CUIDADO:** Os operadores devem ler e compreender este manual completamente antes de usar o produto.

**ATENȚIE:** Operatorii trebuie să citească și să înțeleagă complet acest manual înainte de a utiliza produsul.

**ΠΡΟΣΟΧΗ:** Οι χειριστές πρέπει να διαβάσουν και να κατανοήσουν πλήρως αυτό το εγχειρίδιο πριν από τη χρήση του προϊόντος

**FÖRSIKTIGHET:** Operatörer måste läsa och förstå denna manual helt innan de använder produkten

	REF
<b>GIMA 34260</b>	<b>RE-25710</b>
<b>GIMA 34261</b>	<b>RE-25711</b>
<b>GIMA 34262</b>	<b>RE-25712</b>
<b>GIMA 34263</b>	<b>RE-25113</b>
<b>GIMA 34264</b>	<b>RE-25213</b>



Besmed Health Business Corp.  
 No. 5, Lane 116, Wu-Kong 2nd Road, Wu-Ku District,  
 New Taipei City 24888, Taiwan  
 Made in Taiwan



Casus Europe B.V.  
 Lange Viestraat 2b, 3511 BK Utrecht  
 The Netherlands



**Gima S.p.A.**  
 Via Marconi, 1 - 20060 Gessate (MI) Italy  
 gima@gimaitaly.com - export@gimaitaly.com  
[www.gimaitaly.com](http://www.gimaitaly.com)



## **1. PRODUCT DESCRIPTION AND INTENDED USE**

Besmed Reusable Resuscitator is manufactured by using 100% medical grade Silicone, and is designed for use as an adjunct to artificial respiration and cardiopulmonary resuscitation. The designs are also different according to Adult, Child or Infant by using different Non-rebreathing Valve and Silicone Bag.

- This device is intended for use by qualified medical and emergency personnel trained in pulmonary ventilation and advanced cardiac life support techniques.
- Only qualified personnel trained in the use of positive end expiratory pressure (PEEP) should administer PEEP with this device.

## **2. WARNINGS & CAUTIONS**

### **Warnings**

1. Do not use the resuscitator in toxic or hazardous environments.
2. Do not use the product if contaminated by external sources to prevent infection.
3. Do not use the product if any of the functionality test fails, as this can lead to reduced or no ventilation.
4. Do not administer supplemental oxygen in the presence of open flames, oil, grease, and other flammable chemicals, as this may cause explosion.
5. Do not override the pressure relief valve unless it is considered necessary by a medical professional.
6. Always monitor airway pressure with a manometer when ventilating a patient.
7. Adding accessories may increase and/or expiratory resistance. Do not attach accessories if increased breathing resistance would be detrimental to the patient.
8. Rx only incorrect use of this product might harm the patient.
9. When using the resuscitator with a face mask, make sure the positioning and sealing of the face mask are correct.
10. Do not lubricate fittings, connections, tubing, or other accessories of the resuscitator to avoid the risk of fire and burns.
11. Avoid using an oxygen concentration more than that which is clinically required by the patient. Delivering excessive oxygen can increase the risk of oxygen toxicity e.g. pulmonary damage, retinopathy of prematurity.
12. Patient expired gas is potentially infectious. Breathing filters can reduce but not eliminate contamination risk.
13. Incorrect use of this device can lead to excessive patient rebreathing and death.
14. Use the correct size resuscitator for the ideal body mass of the patient to avoid the risk of hypoventilation



#### 4. PRINCIPLES OF OPERATION

The Figure ① shows Besmed Reusable Resuscitator is composed of 4 components:

- (A) Non-rebreathing Valve (with Pressure Relief Valve)
- (B) Silicone Bag
- (C) Intake Valve (All in one)
- (D) Oxygen Reservoir

The Oxygen Reservoir (D) should be removed if supplemental oxygen is not to be supplied.

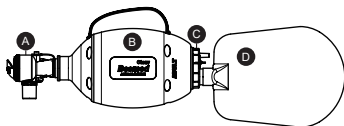
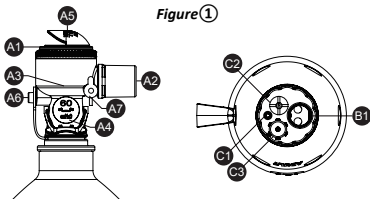

Figure ①



- A1. Expiration Port
- A2. Patient Port
- A3. One-way Valve
- A4. Pressure Relief Valve

- A5. Diverter Cap
- A6. Pressure Manometer Port
- A7. Medication Port
- B1. Reservoir Valve

- C1. Oxygen Supply Port
- C2. Air inlet Valve
- C3. Excess Air Valve

#### Inspiration

- When compressing down the Silicone Bag (B) of resuscitator, it creates the positive pressure and close the Reservoir Valve (B1) and Air inlet Valve (C2), the air inside the bag pushes the One-way Valve (A3) upward, and block the Expiration Port (A1), then deliver the air to the Patient Port (A2).
- If oxygen is in use, it should be connected by Oxygen Supply Port (C1), then the oxygen will fill up the Oxygen Reservoir (D). Exhalation When releasing the Silicone Bag (B), push downward the One-way Valve (A3) to release the exhale air through the Expiration Port (A1).
- Specially designed Excess Air Valve (C3) to release the excessive air and avoid causing too high pressure inside the bag and the reservoir.
- Pressure Relief Valve (A4), any pressure exceed this standard will cause it to jump off and push the pressure out, then keep it within the pressure limit to ensure the patient's safety.
- Lock the Pressure Relief Valve (A4) when higher inspiratory pressure is required as shown in Figure ②.
- The Manometer can be connected to the manometer port (A6) and medication should be administered via the Medication Port (A7) as shown in Figure ②.

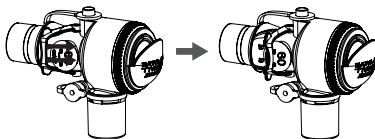

Pressure Relief Valve

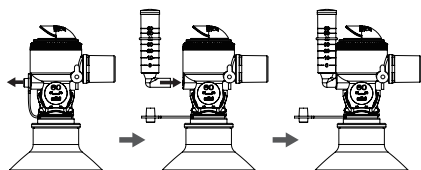

**Pressure Manometer Port**

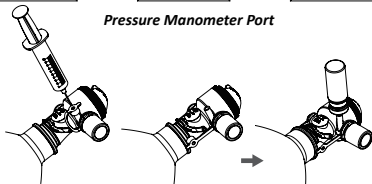

**Medication Port**

**Figure ②**

## 5. OPERATING INSTRUCTION

1. Place the patient on back, pull his chin upward to keep the airway and the mouth cavity in alliance line, so the patient can breathe smoothly.
2. Clean all visible foreign material inside the mouth and the throat.
3. Keep the patient's mouth open to prevent tongue from occluding the airway.

**Remark: If the patient already has an airway inner tube inserted, or has been – through an airway excise resect operation, then please remove the mask, connect the Non-rebreathing Valve connector with the airway inner tube, then following the standard operating instruction.**

4. Cover the patient's mouth and nose with the mask, and press palm against the mask to keep it close to the patient's face.
5. The emergency personnel should check to ensure that the patient is ventilating properly as shown in

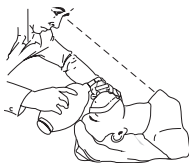

**Figure ③.**

### NOTE:

- Observe rise and fall of the patient's chest (accordingly with the pressing on the Resuscitator).
- Check the patient's lips and face color through the transparent part of the mask and check that the interior of the mask is being fogged during exhalation.
- Check that the patient valve is working properly through the transparent housing.
- If the patient vomits during mask ventilation, immediately clear the patient's airway and then freely compress the bag a few times before resuming ventilation.
- The Non-rebreathing Valve may be disassembles and cleaned if excessive amount of vomitus.

## 6. CLEANING, DISINFECTION AND STERILIZATION PROCESSES & REASSEMBLY

- The resuscitator must be disassembled as shown in Figure ④ before the processes. Do not disassemble the

pressure relief valve spring.

- When and parts for the processes:

- For parts exposed to expiratory gases (non-rebreathing valve) do the processes after each patient.
- If the resuscitator is used for patients/environments with infectious diseases do the processes for the whole set of the resuscitator.

**NOTE:**

- Use only brands that are suitable for the resuscitator materials to avoid causing damage and reduction in the lifetime of the materials.
- Follow the instructions of the manufacturer of the operation and detergent or chemical disinfectant for dilution and exposure time.
- Substances containing phenol should be avoided. Phenol may cause premature wear and degradation of the materials or reduce the time use of the product.
- Promptly remove all residue of cleaning materials from the resuscitator to avoid causing premature wear or reduce the time use of the product.
- The following methods are generally recommended. Select proper methods for the resuscitator parts in question according to the table.

**Cleaning Method:**

Manual washing: Wash the components thoroughly by a soft brush in warm clean tap water containing a mild detergent, e.g., MediClean Forte. After washing, rinse the parts thoroughly in clean water to remove any residues of detergent.

**Disinfection Method:**

Aldehyde or other chemical liquid, e.g., Cidex. After exposing the resuscitator parts to the chemical disinfectant, rinse all parts of the resuscitator set thoroughly in clean water to remove the residues.

**Sterilization Method:**

Autoclaving (max 121°C): Can be used on all parts of the resuscitator, except PVC (Oxygen Tubing) and PE (Oxygen Reservoir) material products.

- Besmed Reusable Resuscitator test has shown that is still fully functional following autoclaved while maintaining full functionality will vary, and can be both higher and lower than 40 times, depending on product use, storage, and tear. Always perform a test of function prior to each use.

**Visual Inspection and Reassembly:**

1. After the processes, let the resuscitator parts stay at room temperature to dry. Wait until all parts are dry. No drying agent is needed.
2. After the processes carefully inspect all parts for damage or excessive wear and replace them if necessary. Some methods may cause discoloration of rubber parts but will not affect their lifetime. In case of material deterioration, e.g. cracking, the parts should be replaced. Contact your distributor for part replacement.
3. Assemble the parts as shown in Figure ④ but in reverse order.

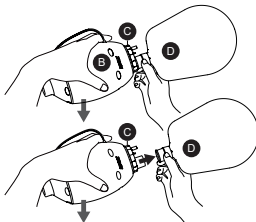
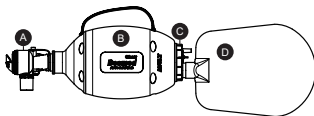

Applicable	Cleaning (Washing)	Disinfecting	Sterilization
Part	Manual Washing (MediClean Forte, etc.)	Chemicals (Cidex, etc.)	Autoclaving (Max 121°C)
A) Non-Rebreathing Valve (with Pressure Relief Valve)	○	○	○ (PP, PC, Silicone)
(B) Silicone Bag	○	○	○ (Silicone)
(C) Intake Valve (All in one)	○	○	○ (PC, Silicone)

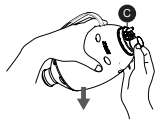

(D) Oxygen Reservoir	X	X	X (PVC)
Oxygen Tubing	X	X	X (PVC)
Mask	O	O	O (Silicone)

"O" Applicable; "X" Not Applicable

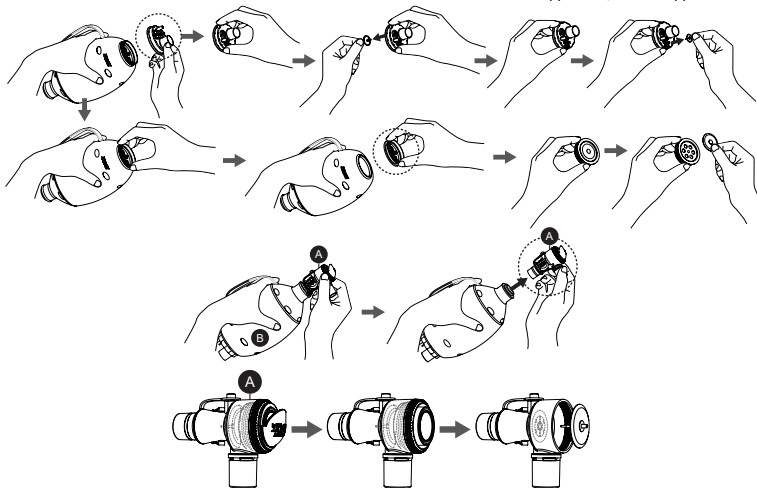

Figure 4

## 7. STORAGE

- Storage temperature:  $-40^{\circ}\text{C}$  to  $60^{\circ}\text{C}$  ( $-40^{\circ}\text{F}$  to  $140^{\circ}\text{F}$ ).
- For compact storage, e.g. in an emergency case, the inlet end can be pushed halfway into the bag.
- Never excessively squeeze, compressed or fold the bag during storage.
- For long-term storage or transportation the resuscitator should be kept in closed packing in a cool place and away from direct sunlight.

## 8. TEST OF FUNCTION

The Besmed Reusable Resuscitator should be tested:

1. When first using the new Resuscitator.
2. After cleaning and sterilizing.
3. After any new parts have been fitted.
4. Monthly, if the Resuscitator is not frequently used.
  - Equipment required: Test lung, Pressure Manometer, Flow meter, Gas supply, Gas supply tubing.

### Resuscitator:

1. Remove the non-rebreathing valve, the oxygen reservoir and intake valve.
2. Compress the silicone bag and block the non-rebreathing valve outlet.
3. Release the bag. The bag should expand immediately and refill. If not, check that the Reservoir Valve at the base of the silicone bag is correctly assembled.

- While keeping the non-rebreathing valve outlet blocked, compress the bag again. The bag should not compress easily. If this occurs, check that you are blocking the valve sufficiently, and that the reservoir valve at the base of the silicone bag is correctly assembled.

#### Non-rebreathing Valve:

- Connect the non-rebreathing valve to the silicone bag and test lung.
- Compress and hold the bag. The One-way Valve should open and the test lung should inflate during the compressed session. If not, check the connection between the Resuscitator and the test lung, and check that the non-rebreathing valve is correctly assembled.
- Release the bag. The One-way Valve should close and as the test lung deflates, gas should flow through the expiratory port via the non-rebreathing valve. If not, check that the non-rebreathing valve is correctly assembled.

#### Pressure Relief Valve:

- Connect a Pressure manometer to the patient outlet of the non-rebreathing valve.
- Compress the bag. When the pressure relief valve activates, the Pressure manometer should read 35-40 cmH<sub>2</sub>O or 55-60 cmH<sub>2</sub>O in adult. If not, check that the non-rebreathing valve is correctly assembled and does not leak. If the pressure relief valve fails a further test, it must be replaced.

#### Oxygen Reservoir / Intake Valve:

- Attach the Reservoir to the Intake Valve. Attach the Silicone bag.
- Inflate the Reservoir and block the Oxygen Supply Port.
- Compress the Reservoir bag. Gas should escape through the Reservoir valve and Excess Air Valve. If not, check that the Intake Valve is correctly assembled.
- Cycle the Resuscitator through several ventilations. The Excess Air Valve should open during each refill to allow room air to enter the silicone bag. If not, check that the Intake Valve is correctly assembled.

#### NOTE:

If supplemental oxygen is not connected, the silicone bag will refill more slowly if the reservoir is still attached.

#### Overall Function

- Fully assemble the Resuscitator (non-rebreathing valve, silicone bag, and intake valve and oxygen reservoir). Connect the Resuscitator to a supplemental gas source and connect a test lung to the patient outlet on the non-rebreathing valve.
- Set the supplemental gas flow to 15 LPM.
- Cycle the Resuscitator through several ventilations. The test lung should inflate during inspiration and deflate during exhalation. Check for leakage at all joints and connections. Ensure that the Resuscitator refills promptly and properly and that all valves are operating correctly. If not, repeat the tests above to find where the problem lies.

## 9. ASSEMBLY VIEW & ACCESSORIES AND REPLACEMENT PARTS

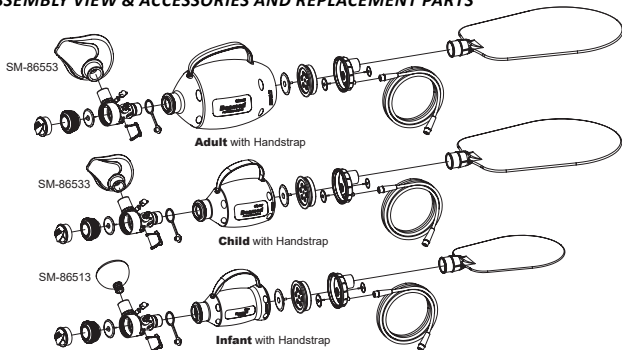

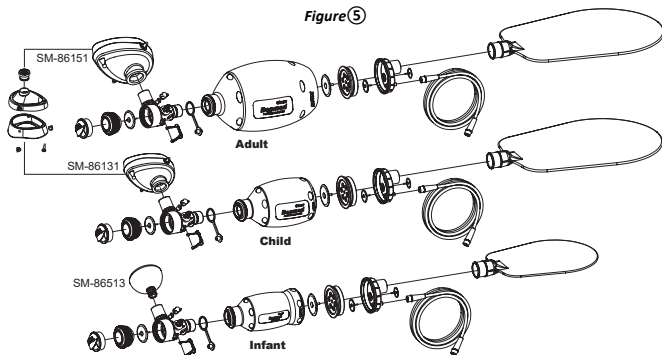
**Figure 5**

**Besmed Reusable Resuscitator Accessories**

Reusable Resuscitator, 60cmH <sub>2</sub> O POP-OFF, 1600ml, Adult
Reusable Resuscitator, 40cmH <sub>2</sub> O POP-OFF, 500ml, Child
Reusable Resuscitator, 40cmH <sub>2</sub> O POP-OFF, 280ml, Infant
Reusable Resuscitator with Handstrap, 60cmH <sub>2</sub> O POP-OFF, 1600ml, Adult
Reusable Resuscitator with Handstrap, 40cmH <sub>2</sub> O POP-OFF, 500ml, Child
Reusable Resuscitator with Handstrap, 40cmH <sub>2</sub> O POP-OFF, 280ml, Infant
Non-Rebreathing Valve 40cmH <sub>2</sub> O
Non-Rebreathing Valve 60cmH <sub>2</sub> O
Intake Valve (All in One)
Oxygen Reservoir 1L/ 2.5L
Durable PEEP Valve 2-10 cmH <sub>2</sub> O (Orange) ID: 15mm/ ID: 30mm
Durable PEEP Valve 5-20 cmH <sub>2</sub> O (Blue) ID: 15mm/ ID: 30mm
Pressure Manometer 0-60 cmH <sub>2</sub> O, Straight Type/ L Type
Hanging Ring
Oxygen Tubing, 7Ft
Silicone Mask, Size 1
Silicone Mask, Size 3, Child Large/ Silicone Mask, Size 3
Silicone Mask, Size 5, Adult Large/ Silicone Mask, Size 5

**PEEP Valve**

**Manometer**
**10. BESMED PEEP VALVE (ACCESSORY SERIES)**

Besmed Peep Valve is designed for use with the Reusable Resuscitator to introduce the positive end-expiratory pressure during the ventilation. The use of the PEEP Valve will not affect inspiratory resistance or inspiratory oxygen concentration, and it can be used both during the treatment for breathing recovery and

breathing difficulties.

### Technical Specification

Color	Durable PEEP Valve		Disposable PEEP Valve	
	Orange	Blue	Orange	Blue
Adjustable Range	2-10 $\pm$ 2cmH <sub>2</sub> O	5-20 $\pm$ 2cmH <sub>2</sub> O	2.5-10 $\pm$ 2cmH <sub>2</sub> O	5-20 $\pm$ 2cmH <sub>2</sub> O
Connection Port	ID: 30mm and 15mm		ID: 30mm or 15mm	
Adaptor	30M to 22M/15F			
Materials	PC, Silicone, Stainless Steel			

### User's Manual

- Expiration Port with Diverter Cap toward the direction away from the patient or the Emergency Personnel's position.
- Compress the Resuscitator a few times to make sure all functions are normal after assembly.
- Choose the proper Peep Valve within the specification range.
- Turn the knob of the Peep Valve to the needed manometer indicated on the valve base.
- Remove the Diverter Cap on the Expiration Port and attach the Peep Valve to the Expiration Port as shown in Figure ⑥.
- Press on the Resuscitator for air exchange motion of the breathing bag, and adjust for the proper Peep Valve pressure needed on the Peep Valve.
- For Durable PEEP Valve, regularly clean and sterilize before and after use.

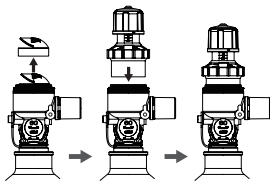

















Figure ⑥

### LEGEND OF SYMBOLS

	Medical Device compliant with Directive 93/42/EEC		Product code
	Importated by		Manufacturer
	Please read instructions carefully		Date of manufacture
	Lot number		Disposable device, do not re-use
	Expiration date (see box / package)		Keep in a cool, dry place
	Keep away from sunlight		Authorized representative in the European community
	Not made with natural rubber latex		No-DEHP formulation
	Temperature limit		Non-sterile

**MD**

Medical Device

**GIMA WARRANTY TERMS**

The Gima 12-month standard B2B warranty applies.