

DIGITAL BLOOD PRESSURE MONITOR



# RBP-100

Instruction for use

CE 0124

 **Riester**

## TABLE OF CONTENT

1. Introduction
  - 1.1 Important information read prior to start-up
  - 1.2 Safety Information and electromagnetic compatibility
  - 1.3 Packaging symbols
  - 1.4 Intended use
  - 1.5 User Responsibility
  - 1.6 Warnings and Contraindications
2. Using the device for the first time
  - 2.1 Scope of supply
  - 2.2 Device function
  - 2.3 Inserting the battery pack
  - 2.4 Setting the date and time
  - 2.5 Setting the time format (12h or 24h time format)
  - 2.6 Setting interval times for triple BP measurements (3x)
  - 2.7 Deactivation of beeper
3. Before each measurement
  - 3.1 Selecting the correct cuff
  - 3.2 Fitting the cuff
  - 3.3 Selecting the measurement mode
4. Performing BP measurements in different measurement modes
  - 4.1 Standard blood pressure measurement (1x)
  - 4.2 Triple blood pressure measurement (3x)
  - 4.3 Auscultatory/manual blood pressure measurement (MAN)
5. After the measurements
  - 5.1 Blood pressure classification
  - 5.2 Irregular Heartbeat

# RBP-100



- 6. Memory
  - 6.1 Viewing stored values
  - 6.2 Viewing individual values performed in triple BP measurement mode
  - 6.3 Clearing the memory
- 7. Battery indicator and battery pack charge
  - 7.1 Low or empty battery pack
  - 7.2 Mains adapter
- 8. Error Messages
- 9. Safety, Care, Accuracy Test and Disposal
  - 9.1 Safety and protection
  - 9.2 Device care
  - 9.3 Cleaning the cuff
  - 9.4 Accuracy test
  - 9.5 Spare Parts
  - 9.6 Disposal
- 10. Technical Specifications
- 11. EMC
- 12. Warranty









**RBP-100**

## 1. INTRODUCTION

### 1.1 IMPORTANT INFORMATION READ PRIOR TO START-UP















You have purchased a high quality Riester RBP-100, which has been manufactured according to the Directive 93/42 EEC and is subject to the strictest quality controls at all times. Read these instructions for use carefully before putting the unit into operation and keep them in a safe place. If you should have any questions, we are available to answer queries at all times. Our address can be found in these instructions for use. The address of our sales partner will be given upon request. Please note that all instruments described in these instructions for use are only to be used by suitably trained personnel. The perfect and safe functioning of this instrument is only guaranteed when original parts and accessories from Riester are used.

### 1.2 SAFETY INFORMATION AND ELECTROMAGNETIC COMPATIBILITY

| Symbol  | Symbol Note  |
|---|--|
|    | Follow the instructions in the operation manual  |
|    | Type BF applied part   |
|    | Class II isolation equipment   |
| IP20  | IP20: Protected against solide foreign particles with a diameter of more than 12.5mm, no protection against water.   |
|  | Warning  |
|  | Note   |
|  | Ensure that children do not use this device unsupervised; some parts are small enough to be swallowed. Be aware of the risk of strangulation in case this device is supplied with cables or tubes. |
|  | Manufacturing date   |
|  | Manufacturer   |
|  | Manufacturer serial number   |

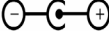



# RBP-100



|   |   |
|---|---|
|    | Lot number  |
|    | Reference number  |
|    | Temperature for transport and storage condition   |
|    | Relative Humidity for transport and storage condition   |
|    | CE Mark   |
|    | Symbol for the marking of electrical and electronics devices according to Directive 2002/96/EC. |
|    | Non-ionizing radiation  |
| SYS<br>mmHg   | Systole   |
| DIA<br>mmHg   | Diastole  |
| PULSE<br>/min   | Heartbeat per minute  |
|    | Mini- USB Socket<br>Only RBP-100 USB  |
|   | On / Off  |
|  | Connector for cuff  |
|  | Positive polarity<br>Mains adapter socket   |
|  | Latex free  |
|  | Washable cuff   |
|  | Instruction use   |
|  | Symbol for Arterie position   |

**RBP-100**

### 1.3 PACKAGING SYMBOLS

| Symbol  | Symbol Note   |
|---|---|
|  | Fragile. Handling should be handled with care.                  |
|  | Beware the package from getting wet.                            |
|  | Upward. It shows the correct position to transport the package. |
|  | Keep away from sunlight   |
|  | "Grüner Punkt" (country-specific)                               |

The instrument satisfies the requirements for electromagnetic compatibility. Please note that under the influence of unfavorable field strengths, e.g. during the operation of wireless telephones or radiological instruments, adverse effects on function cannot be excluded. The electromagnetic compatibility of this device has been verified by test according to the IEC 60601-1-2:2014 / DIN EN 60601-1-2:2016-05 requirements.

### 1.4 INTENDED USE

This oscillometric blood pressure monitor is intended for measuring non-invasive blood pressure in people aged 3 years or older. It is clinically validated in patients with hypertension, hypotension, diabetes, pregnancy, pre-eclampsia, atherosclerosis, end-stage renal disease, obesity and the elderly. This device is intended to be operated by trained personnel only. Examples of trained operators include professional clinical and healthcare personnels.

### 1.5 USER RESPONSIBILITY

Your Riester RBP-100 product is designed to perform in conformity with the description contained in this operation manual and accompanying labels and inserts, when assembled, operated, maintained and repaired in accordance with the instructions provided.

# RBP-100



**Note:**







It is your responsibility to:

- Check calibration of the device every two years.
- Never knowingly use a defective device.
- Immediately replace parts that are broken, worn, missing, incomplete, damaged or contaminated.
- Contact the nearest factory approved service center should repair or replacement become necessary.
- Further, the user of the device bears sole responsibility for any malfunction that results from improper use, faulty maintenance, improper repair, damage or alteration by anyone other than Riester or authorized service personnel.

## 1.6 WARNINGS AND CONTRAINDICATIONS

|  |   |
|--|---|
|  | There is a danger of life-threatening electrical shock.<br>For electrically isolating the device from supply mains pull the plug from the socket outlet.<br>Unplug the instrument before cleaning!                |
|  | At the proposed RBP-100 location the power plug must be accessible.   |
|  | Do not use this device on pediatric patients under 3 years old, infants, or neonates.   |
|  | The Riester RBP-100 is not intended for continuous monitoring. Do not leave the device unattended while taking measurements on a patient.   |
|  | Do not operate the Riester RBP-100 near flammable anesthetics or volatile vapors. An explosion may result.  |
|  | Do not use the device if it has failed its diagnostic self test or if it displays a greater than zero pressure with no cuff attached.   |
|  | Do not make repairs yourself. Equipment must be returned to Riester or authorized service personnel for repairs. Substitution of a component different from that supplied may result in measurement error.        |
|  | The Riester RBP-100 is not intended for patients connected to a cardiopulmonary bypass machine.   |
|  | If Luer Lock connectors are used in the constructions of tubing, there is a possibility that they might be inadvertently connected to intravascular fluid systems, allowing air to be pumped into a blood vessel. |
|  | The Riester RBP-100 must be charged before using it for the first time.   |

# RBP-100

|   |   |
|---|---|
|  | For accurate blood pressure measurements, ensure that the circumference of the arm fits within the range markings on the cuff.  |
|  | Only use such accessories as are recommended for use with this device.  |
|  | Compressing the pneumatic tubing may cause system errors.   |
|  | Prevent water or other fluids from entering any connectors or vents on the device. Should this happen, all connectors should be dried with warm air. Then check the calibration of the device and operating functions before reusing. |
|  | If the Riester RBP-100 is dropped or mishandled, please have it checked by a authorized service center before bringing it back into use.  |
|  | At least every three months, inspect cords and accessories for fraying or other mechanical damage. Replace as necessary.  |
|  | Check the calibration of your Riester RBP-100 at least once every two years.  |

## 2. USING THE DEVICE FOR THE FIRST TIME

### 2.1 SCOPE OF SUPPLY

- 1 pc soft cuff size M (22 - 32 cm / 8.7 - 12.6 inches)
- 1 pc soft cuff size L-XL (32 - 52 cm / 12.6 - 20.5 inches)
- 1 pc 2.5 m air tube with metal connector
- 1 pc AC/DC Adapter 7.5 V / 1500 mA
- 1 pc NIMH AA 4.8 V 2400 mAh rechargeable battery-pack
- 1 pc instruction booklet

### 2.2 DEVICE FUNCTION

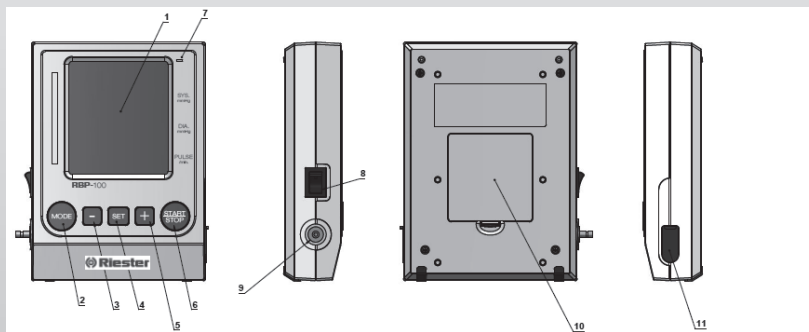

# RBP-100



## Cuff

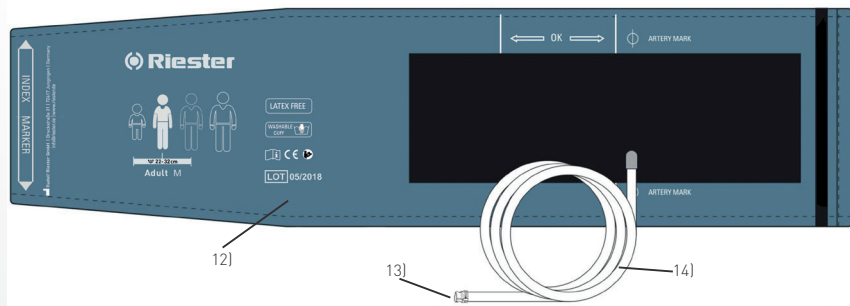

- 1) Display
- 2) Mode button
- 3) Start/Stop button
- 4) SET button (settings)
- 5) Plus button (+)
- 6) Minus button (-)
- 7) LED battery indicator
- 8) Power switch
- 9) Cuff socket
- 10) Battery compartment
- 11) Mains adapter socket
- 12) Cuff
- 13) Cuff connector
- 14) Cuff tube

**RBP-100**

## Display

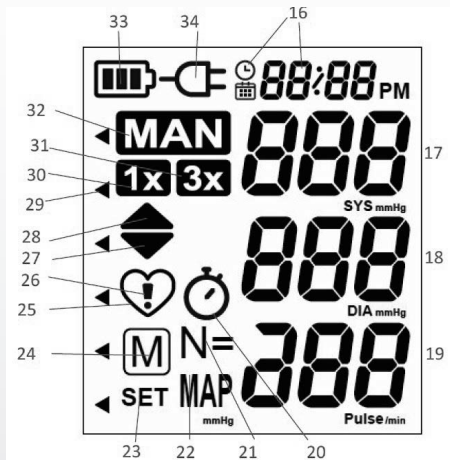

- 16) Date and time
- 17) Systole
- 18) Diastole
- 19) Pulse rate
- 20) Interval time symbol (3x measurement)
- 21) Number of stored data
- 22) Mean Arterial Pressure (MAP)
- 23) Settings
- 24) Memory
- 25) Pulse indicator
- 26) Irregular Heartbeat (IHB)
- 27) Cuff deflation
- 28) Cuff inflation
- 29) Blood pressure classification (WHO)
- 30) Standard BP measurement (1x) mode
- 31) Triple BP measurement (3x) mode
- 32) Auscultatory / Manual BP measurement (MAN) mode
- 33) Battery display
- 34) Mains adaptor symbol

# RBP-100



## 2.3 INSERTING THE BATTERY PACK

- 2.3.1 Open the battery compartment (10) on the backside of the device.
- 2.3.2 Connect the cable of the rechargeable battery pack with the cable, that is inside of the battery compartment.
- 2.3.3 Insert the battery pack and close the battery compartment.
- 2.3.4 Plug in the mains adapter into the mains adapter socket (11) and fully charge the batterypack until the LED battery indicator (7) is lightning in green.
- 2.3.5 Switch the power switch (8) on.
  - When you press a button, the backlight is active for 10 seconds. Without further operation, after 10 seconds the backlight automatically turns off.

## 2.4 SETTING THE DATE AND TIME

- 2.4.1 To adjust date and time, press the SET button (4) once to enter the settings menu; cycle between different adjustments using "+"(5) and "-"(6) buttons until SET (23), and the clock /calendar icons (16) appears in the display.
- 2.4.2 Press the SET button (4) to enter date and time adjustment. Upon entering date and time adjustment, year will blink.
- 2.4.3 Press the "+" (5) and/or "-"(6) buttons to adjust the year; press the SET button to confirm the adjustment. The next adjustment – month – will appear and blink.
- 2.4.4 Follow the instructions above to adjust the settings of month, day, hour, and minute. Press and hold "+" (5) or "-" (6) button for fast increment and decrement.
- 2.4.5 Once you have set the minutes and pressed the SET button, the device moves back to Stand-by Mode.
  - Press the Start/Stop button (3), if you want to abort the time adjustment and return to stand-by mode.

## 2.5 SETTING THE TIME FORMAT (12H OR 24H TIME FORMAT)

- 2.5.1 To set the time format, press the SET button (4) once to enter the settings menu; cycle between different adjustments using "+"(5) and "-"(6) buttons until SET (23), the clock icon and "PM" (16) appears in the display.
- 2.5.2 Press SET button (4) again to enter time format adjustments; SET (23) and current time format (24H: 18:00 or 12H: 06:00 PM) will appear.
- 2.5.3 You can now select between 12h and 24h time format by pressing the "+" (5) and "-" (6) buttons.

**RBP-100**

2.5.4 Confirm the selected time format by pressing the SET button. To exit without making changes, press "Start/Stop" button (3).

- The device is delivered with default setting of 24h time format.

## **2.6 SETTING INTERVAL TIMES FOR TRIPLE BP MEASUREMENTS (3X)**

2.6.1 To change the interval time settings, press the SET button (4) once to enter the settings menu, then cycle between different adjustments using "+"(5) and "-"(6) buttons.

2.6.2 Press the SET button (4) when the symbols for triple BP measurement (30), interval symbol (20) and SET (23) appear in the display, to enter interval time adjustment.

2.6.3 You can now choose between different interval times of 15 seconds, 30 seconds, 45 seconds or 60 seconds by pressing repeatedly the "+" or "-" buttons (5/6).

2.6.4 Confirm your selection by pressing the SET button while the selected interval time is shown on the display. To exit without making changes, press "Start/Stop" button (3).

- The device is delivered with default setting of 15 seconds interval time.

## **2.7 DEACTIVATION OF BEEPER**

During blood pressure measurements, the pulse indicator (25) flashes in the display and a beep sounds every time a heartbeat is detected.

2.7.1 To deactivate the beeper, press the SET button (4) once to enter the settings menu, then cycle between different adjustments using "+"(5) and "-"(6) buttons.

2.7.2 Press the SET button (4) when "BEEP" and SET (23) appear in the display, to enter beeper adjustment.

2.7.3 Select „Off" or „On" by pressing the "+" (5) or "-" (6) buttons.

2.7.4 Confirm your selection by pressing the SET button. To exit without making changes, press "Start/Stop" button (3).

- The device is delivered with default setting activated beeper.

## **3. BEFORE EACH MEASUREMENT**

### **3.1 SELECTING THE CORRECT CUFF**

Riester offers different cuff sizes. Select the cuff size to match the circumference of your patients upper arm (measured by close fitting in the centre of the upper arm).

# **RBP-100**



| Cuff size  | For circumference of upper arm  |
|------------|---------------------------------|
| S (option) | 14-22 cm (5.5 – 8.7 inches)     |
| M          | 22 - 32 cm (8.7 - 12.6 inches)  |
| L-XL       | 32 – 52 cm (12.6 - 20.5 inches) |

- 3.1.1 Always ensure that the correct cuff size is used [size markings on the cuff]
- 3.1.2 Contact your local Riester service if the enclosed cuffs (12) do not fit.
- 3.1.3 Connect the cuff to the device by clicking the cuff connector (13) on to the cuff socket (8).

 Only use Riester cuffs.

## 3.2 FITTING THE CUFF

- 3.2.1 Remove close-fitting garments from the upper arm of the patient. To avoid constriction, shirt sleeves should not be rolled up - they do not interfere with the cuff if they are laid flat.
- 3.2.2 Position the cuff on the upper arm (right or left), so that the tube points in the direction of the lower arm.
- 3.2.3 The artery mark on the cuff must lie over the artery which runs down the inner side of the arm.
- 3.2.4 Make sure that the cuff is positioned 2-3 cm above the elbow.
- 3.2.5 Secure the cuff with the Velcro and make sure the cuff is comfortably attached and not too tight.
- 3.2.6 Lay the arm of the patient on the table (palm upwards), so that the cuff is at the same height as the heart.
- 3.2.7 Make sure that the tube is not kinked.

## 3.3 SELECTING THE MEASUREMENT MODE

This device allows you to measure in three different measurement modes. Select between Standard BP Measurement 1x (30), Triple BP Measurement 3x (31) and Manual BP Measurement (32) by pressing repeatedly the Mode button (2). The current set measurement mode is on the display shown by the related symbol.

**RBP-100**

## 4. PERFORMING BP MEASUREMENTS IN DIFFERENT MEASUREMENT MODES

### 4.1 STANDARD BLOOD PRESSURE MEASUREMENT (1X)

- 4.1.1 Select the standard BP measurement mode by pressing repeatedly the Mode button (2) until 1x (30) appears on the display.
- 4.1.2 Press the Start/Stop button (3) to start the measurement.
- 4.1.3 The cuff will now pump up automatically. The inflation is indicated by the blinking cuff inflation symbol (28). The patient should relax, should not move and should not tense his arm muscles until the measurement result is displayed. He should breathe normally and not talk.
- 4.1.4 When the correct pressure is reached, the pumping stops and the pressure falls gradually. The deflation is indicated by the blinking cuff deflation symbol (27). If the required pressure was not reached, the device will automatically pump some more air into the cuff.
- 4.1.5 During the measurement, the pulse indicator (25) flashes in the display and a beep sound appears each time a heartbeat is detected.
- 4.1.6 The result, comprising the systolic (17) and the diastolic (18) blood pressure, pulse rate (19) and mean arterial pressure (MAP) (22). The results of pulse rate and mean arterial pressure alternating appear on the display every 2 seconds.
- 4.1.7 When the device has finished measuring, remove the cuff.
- 4.1.8 Switch off the device (The monitor does switch off automatically after approx. 1 min.).



#### Note:

- Manual inflation: If the systolic blood pressure of a patient is known to be very high, it is possible to set the pressure individually. Press the Plus button (5) after the monitor has been pumped up to a level of approx. 30 mmHg (shown on the display). Keep the button pressed until the pressure is about 40 mmHg above the expected systolic value – then release the button.
- Manual rapid cuff deflation: Press and hold the Minus button (6) when you want to deflate the cuff rapidly.
- You can stop the measurement at any time by pressing the ON/OFF button (e.g. if your patient feel uneasy or an unpleasant pressure sensation).

### 4.2 TRIPLE BLOOD PRESSURE MEASUREMENT (3X)

- 4.2.1 Select the triple BP measurement mode by pressing repeatedly the Mode button (2) until 3x (31) appears on the display.
- 4.2.2 Press the Start/Stop button (3) to start the measurement.

# RBP-100



- 4.2.3 There is an interval between measurements. A count down indicates the remaining time, then the device repeats the measurement. If beeper is activated beep will sound when count down reaches 5 seconds.
- 4.2.4 After the result of the second measurement is displayed, the device performs again a countdown and again repeats the measurement.
- 4.2.5 When the whole triple BP measurement episode is completed, the average is calculated. The display then shows the average result, comprising the systolic (17) and the diastolic (18) blood pressure, pulse rate (19) and mean arterial pressure (MAP) (22). The results of pulse rate and mean arterial pressure alternating appear on the display every 2 seconds.



**Note:**

- To skip an interval count down, press the Start/Stop button (3) during count down. Measurement will be initiated immediately.
- The bottom hand section of the display shows "N= "1, 2 or 3 to indicate which of the 3 measurements is currently being taken.
- If one of the individual measurements was questionable, a fourth one is automatically taken.
- Do not remove the cuff between measurements.
- The length of the interval time between the measurements can be adjusted (see chapter 2.5)
- Manual inflation: If the systolic blood pressure of a patient is known to be very high, it is possible to set the pressure individually in each measurement. Press the Plus button (5) after the monitor has been pumped up to a level of approx. 30 mmHg (shown on the display). Keep the button pressed until the pressure is about 40 mmHg above the expected systolic value – then release the button.
- Manual rapid cuff deflation: Press and hold the Minus button (6) when you want to deflate the cuff rapidly.
- You can stop the measurement at any time by pressing the ON/OFF button (e.g. if your patient feel uneasy or an unpleasant pressure sensation).

## **4.3 AUSCULTATORY/MANUAL BLOOD PRESSURE MEASUREMENT (MAN)**

- 4.3.1 Select the manual BP measurement mode by pressing repeatedly the Mode button (2) until MAN (32) appears on the display.
- 4.3.2 Briefly press the Start/Stop button (3) to start the automatic inflation of the cuff (28). The cuff will be inflated automatically to 30-40mmHg above systole. Alternatively, press and hold "+" (5) button after cuff pressure reaches 40mmHg to manually inflate the cuff to pressure of your choice; release "+" (5) button to stop manual inflation.
- 4.3.3 Once peak pressure is reached, the cuff will deflate at 3mmHg per second. The deflation is indicated by the cuff deflation symbol (27).

**RBP-100**

4.3.4 Determine now the Systole by listening to the Korotkoff sounds with a stethoscope. To mark and save the Systole, press briefly the SET button (4) as soon as you heard the Systole sound.

 **Note:**

- To rapidly deflate the cuff between systole and diastole, press and hold “-” (6) button. Release the “-” button to stop manual rapid deflation.

4.3.5 To mark and save the Diastole, press again the SET button (4) as soon as you heard the Korotkoff sound of the Diastole.

 **Note:**

- When Systole or Diastole have not been marked during the measurement, the reading is considered as incomplete and not stored in the memory.
- Manual cuff re-inflation: when you notice the pressure in the cuff is not high enough, you can re-inflate the cuff by pressing and holding the “+” button (5)
- Manual rapid cuff deflation: Press and hold the Minus button (6) when you want to deflate the cuff rapidly.
- You can stop the measurement at any time by pressing the ON/OFF button (e.g. if your patient feel uneasy or an unpleasant pressure sensation).

## 5. AFTER THE MEASUREMENTS

### 5.1 BLOOD PRESSURE CLASSIFICATION

The triangle on the left-hand edge of the traffic light display (27) show you the range within which range the measured blood pressure value lies. Depending on the height of the triangle, the readout value is either within the normal (green), borderline (yellow) or danger (red) range.

Table for classifying blood pressure values in adults in accordance with the World Health Organisation (WHO) in 2003. Data in mmHg.

|   | <b>Range</b>                                   | <b>Systolic</b> | <b>Diastolic</b> |
|---|--|-----------------|------------------|
|   | Blood pressure optimal                         | ↓120            | ↓80              |
| 1 | Blood pressure normal                          | 120-129         | 80-84            |
| 2 | Blood pressure high normal                     | 130-139         | 85-89            |
| 3 | Blood pressure Grade 1 hypertension (mild)     | 140-159         | 90-99            |
| 4 | Blood pressure Grade 2 hypertension (moderate) | 160-179         | 100-109          |
| 6 | Blood pressure Grade 3 hypertension (severe)   | 180↑            | 110↑             |

# RBP-100



The higher value is the one that determines the evaluation. Example: a readout value between 150/85 or 120/98 mmHg indicates «blood pressure too high».

## 5.2 IRREGULAR HEARTBEAT

This device is an oscillometric blood pressure monitor that also analyses irregular heartbeats during measurement. The irregular heartbeat symbol [26] is displayed after the measurement if irregular heartbeats occur during measurement. This device does not replace a cardiac examination, but helps to detect heartbeat irregularities at an early stage.



### Note:

- When you manually re-inflate the cuff, irregular heartbeats are not detected.
- When you manually deflate the cuff rapidly, irregular heartbeats are not detected.

## 6. MEMORY

### 6.1 VIEWING STORED VALUES

Press the "+" [5] or "-" [6] buttons briefly when in standby mode. "M" [24] indicates that you are in the memory mode. The display shows «N=» [21] and a value, e.g. «N=17». This means that there are 17 values in the memory. The reading with the highest memory number is the latest performed measurement. Pressing the "+" [5] or "-" [6] buttons repeatedly enables you to move from one stored value to another.



### Note:

- "0 0 0" is displayed when no measurement data in device memory.
- Each stored reading shows the Systole [17], Diastole [18], pulse rate [19], Mean Arterial Pressure (MAP) [22], measurement mode, time and date. The pulse rate and the MAP alternate on the display every two seconds.
- When an irregular heartbeat was detected during a measurement, this symbol [26] is additionally shown in the stored value.
- Press and hold the "+" [5] or "-" [6] buttons when you want to rapidly move through the stored values.

**RBP-100**

## 6.2 VIEWING INDIVIDUAL VALUES PERFORMED IN TRIPLE BP MEASUREMENT MODE

- 6.2.1 Press the plus button (5) for at least 3 seconds while the device is in standby-mode until a short beep appears.
- 6.2.2 The device will now show you each single measurement result with the operation of measurement 1, measurement 2 and measurement 3.



### Note:

- The bottom hand section of the display shows with "N= "1, 2 or 3 which of the 3 measurements is currently shown.
- Individual BP readings of triple BP measurements are not stored individually in the memory. Only the average is stored.
- Individual BP readings of triple BP measurements are erased when a new triple BP measurement is performed.

## 6.3 CLEARING THE MEMORY

- 6.3.1 Press the Plus button (5) to enter the memory.
- 6.3.2 Press and hold the SET button (4) for more than 5 seconds until "M" (24) and "CL" appears on the display.
- 6.3.3 Confirm clearing the memory by pressing again the SET button. "CL" starts to flash while the memory is being deleted.



### Note:

- Cancel deletion: press the Start/Stop button (3) while «CL» is flashing.

## 7. BATTERY INDICATOR AND BATTERY PACK CHARGE

### 7.1 LOW OR EMPTY BATTERY PACK

The device features a built-in, rechargeable NIMH battery pack that delivers up to 1000 measurement cycles. The battery can be recharged between uses with the power adaptor provided. Battery charging indicator is displayed when the rechargeable battery is being charged.

When the battery pack is approximately  $\frac{3}{4}$  empty the battery symbol (32) appears (partly filled battery displayed). Although the device will continue to measure reliably, you should obtain to charge the device soon.

# RBP-100



When the battery pack is flat, the battery symbol (32) will flash as soon as the device is switched on (flat battery displayed). You cannot take any further measurements and you firstly must recharge the device with the delivered mains adapter.



**Note:**

- The memory retains all stored values.
- It takes approximately 6 hours to fully recharge the battery pack. Note that as battery pack ages the recharge time will increase.

## 7.2 MAINS ADAPTER

You can charge this device by using the Riester mains adapter (AC/DC 7.5V, 1500 mA). Additionally, the mains adapter also enables to use the blood pressure monitor without inserted battery pack.

7.2.1 Plug the adapter cable into the mains adapter socket (11) in the blood pressure monitor.

7.2.2 Plug the adapter plug into the wall socket.

7.3.3 The mains adaptor symbol appears (33) and the LED battery indicator (7) turns orange while the battery pack is being recharged.

- The LED battery indicator turns green as soon as the battery pack is fully recharged.





**Note:**

- Only use the Riester mains adapter available as an original accessory appropriate for your supply voltage.
- Ensure that neither the mains adapter nor the cable are damaged.

# RBP-100

## 8. ERROR MESSAGES

If an error occurs during the measurement, the measurement is interrupted and an error message, e.g. «ERR 3», is displayed.

| Error   | Description                                    | Potential cause and remedy  |
|---------|--|---|
| «ERR 1» | Signal too weak                                | The pulse signals on the cuff are too weak. Re-position the cuff and repeat the measurement.  |
| «ERR 2» | Error signal                                   | During the measurement, error signals were detected by the cuff, caused for instance by movement or muscle tension. Repeat the measurement, pay attention the patient is keeping his arm still.   |
| «ERR 3» | Abnormal cuff pressure / inflation / deflation | An adequate pressure cannot be generated in the cuff. A leak may have occurred. Check that the cuff is correctly connected and is not too loose. Replace the batteries if necessary. Repeat the measurement.  |
| «ERR 5» | Abnormal result                                | The measuring signals are abnormal and no result can therefore be displayed. Read through the checklist for performing reliable measurements and then repeat the measurement.   |
| «HI»    | Pulse or cuff Pressure too high                | The pressure in the cuff is too high (over 299 mmHg) OR the pulse is too high (over 200 beats per minute). The patient needs to relax for 5 minutes and then repeat the measurement.<br><br> <b>Note:</b><br>- Irregular heartbeat detection is inactivated when pulse or pressure are lying above these limits. |
| «LO»    | Pulse too low                                  | The pulse is too low (less than 40 beats per minute). Repeat the measurement.<br><br> <b>Note:</b><br>- Irregular heartbeat detection is inactivated when pulse is below this limit.  |

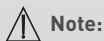

**Note:**

- When an error occurred during the measurement, the reading is not stored in the memory.

# RBP-100



## 9. SAFETY, CARE, ACCURACY TEST AND DISPOSAL

### 9.1 SAFETY AND PROTECTION

- 9.1.1 Follow instructions for use. This document provides important product operation and safety information regarding this device. Please read this document thoroughly before using the device and keep for future reference.
- 9.1.2 This device may only be used for the purposes described in these instructions. The manufacturer cannot be held liable for damage caused by incorrect application.
- 9.1.3 This device comprises sensitive components and must be treated with caution. Observe the storage and operating conditions described in the «Technical Specifications» section.
- 9.1.4 Protect it from:
  - water and moisture
  - extreme temperatures
  - impact and dropping
  - contamination and dust
  - direct sunlight
  - heat and cold
- 9.1.5 The cuffs are sensitive and must be handled with care.
- 9.1.6 Do not exchange or use any other kind of cuff or cuff connector for measuring with this device.
- 9.1.7 Only pump up the cuff once fitted.
- 9.1.8 Do not use this device close to strong electromagnetic fields such as mobile telephones or radio installations. Keep a minimum distance of 3.3 m from such devices when using this device.
- 9.1.9 Do not use this device if you think it is damaged or notice anything unusual.
- 9.1.10 Never open this device.
- 9.1.11 If the device is not going to be used for a prolonged period the batteries should be removed.
- 9.1.12 Read the additional safety information provided within the individual sections of this instruction manual.



Ensure that children do not use this device unsupervised; some parts are small enough to be swallowed. Be aware of the risk of strangulation in case this device is supplied with cables or tubes.

**RBP-100**

## 9.2 DEVICE CARE

Cleaning and disinfection of medical products are meant to protect patients, users, and third persons and lead to value retention of medical products. Due to product design and materials used, there is no possibility to define the maximum limit of re-processing cycles. Lifetime of medical products is determined by its function and gentle use. Before sending back defective products for repair, the described re-processing cycles have to be applied and followed.

Use a soft cloth and follow one of the methods listed for cleaning the exterior of the device:

9.2.1 Mild soap and water

9.2.2 Hydrogen peroxide solution (3% diluted with water)

9.2.3 Sodium hypochlorite solution (1 to 10 dilution of household chlorite bleach in water).



**Note:**

- To prove if all display segments and the display illumination unit are working correctly, press and hold the "+" (5) or "-" (6) buttons. All display segments appear and the display illumination should activate.

## 9.3 CLEANING THE CUFF

Carefully remove spots on the cuff with a damp cloth and soapsuds.



**WARNING:** Do not wash the cuff in a washing machine or dishwasher!

## 9.4 ACCURACY TEST

We recommend that this device is tested for accuracy every 2 years or after mechanical impact (e.g. being dropped). Please contact your local Riester Service to arrange the test.

**Monitoring of instruments**

**All countries except for Germany:**

The respective legal provisions apply for all countries, except for Germany. The reference manometer, which is used for calibration, must be traceable to national and international measurement standards.

It is not allowed to make changes to the device!

# RBP-100



## 9.4.1. VERIFICATION OF CALIBRATION (STATIC)

Test equipment:

Equipment Required:

- 9.4.1.1 Calibrated reference manometer (1) or equivalent (pressure reference).
- 9.4.1.2 500ml volume (3).
- 9.4.1.3 Hand Inflation Bulb (4) with Bleed valve (pressure control).
- 9.4.1.4 Blood pressure device (2) to be tested.

To perform Calibration Verification, proceed as follows:

- 9.4.1.6 Make the necessary connections using the materials listed in the Equipment Required list. See Figure 1 for pneumatic connections.
- 9.4.1.7 Enter the calibration verification mode at the RBP-100: The device must be switched off. Press the Start / Stop button and turn on the power switch at the same time.

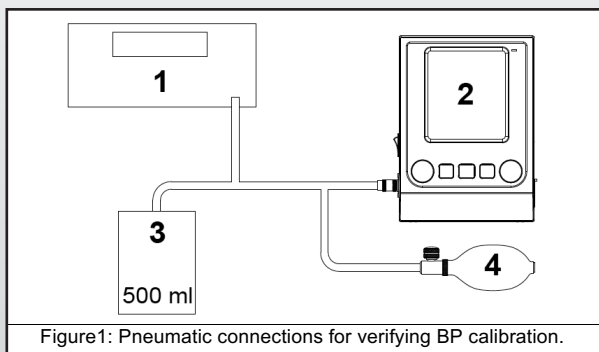

Figure1: Pneumatic connections for verifying BP calibration.

**RBP-100**

9.4.1.8 Please wait until this screen appears.



9.4.1.9 Example for the correct value reading.



- 9.4.1.20 Pump via the Hand Inflation Bulb (4) up to 300mmHg.  
Compare the pressure displayed on the screens of the device and the calibrated reference manometer.
- 9.4.1.21 Then carefully release the air via the Hand Inflation Bulb (4) and stop at the value of 250mmHg. Compare the pressure displayed on the screen of the device and the calibrated reference manometer.  
Note the displayed value on the RBP-100.  
Note the displayed value at the calibrated reference manometer.
- 9.4.1.22 Please repeat these steps at the values of 200-150-100-50-0mmHg.  
Note the displayed value on the RBP-100.  
Note the displayed value at the calibrated reference manometer.
- 9.4.1.23 Please check the readings on the RBP-100 against the value according to the manometer values shown in Table 1 below.

# RBP-100



| Pressure<br>(mmHg on calibrated reference<br>manometer) | Pressure<br>(mmHg as read by RBP-100) |
|---|---------------------------------------|
| 250   | 247 - 253                             |
| 200   | 197 - 203                             |
| 150   | 147 - 153                             |
| 100   | 97 - 103                              |
| 50  | 47 - 53                               |
| 0   | 0 - 3                                 |

**Table 1:** Pressure Verification Table

- 9.4.1.24 If the difference between the calibrated manometer and the RBP-100 is  $< 3$ mmHg for all manometer values, the BP module is calibrated correctly for operation.
- 9.4.1.25 If the difference is  $> 3$ mmHg for any manometer value, then the RBP-100 needs to be calibrated. Contact an authorized service center (see point 13).
- 9.4.1.26 Press the Start / Stop button to exit the calibration verification mode.

## 9.4.2. VERIFICATION OF CALIBRATION (DYNAMIC)



### Note:

For dynamic testing of the RBP-100 we recommend the Fluke (Biomedical) ProSim 8 Vital Signs Simulator.

## 9.5 SPARE PARTS

### 9.5.1 SPARE PART LIST

|                       |   |
|-----------------------|---|
| Art. No. <b>162</b>   | Cuff size S 14-22 cm (5.5 – 8.7 inches)         |
| Art. No. <b>163</b>   | Cuff size M 22 - 32 cm (8.7 - 12.6 inches)      |
| Art. No. <b>164</b>   | Cuff size L-XL 32 – 52 cm (12.6 - 20.5 inches)  |
| Art. No. <b>10697</b> | Air tube with connectors 2,5 m                  |
| Art. No. <b>10696</b> | NiMH Battery Pack 4,8V 2400mAh                  |
| Art. No. <b>10698</b> | AC/DC Adapter 7,5V 1500mAh (EU, US, UK, Austr.) |

## 9.6 DISPOSAL



Batteries and electronic devices must be disposed of in accordance with the locally applicable regulations, not with domestic waste.

# RBP-100

## 10. TECHNICAL SPECIFICATIONS

|                              |  |
|------------------------------|--|
| Operating conditions:        | 10 - 40 °C / 50 - 104 °F<br>15 - 95 % relative maximum humidity  |
| Storage conditions:          | -20 - +55 °C / -4 - +131 °F<br>15 - 95 % relative maximum humidity   |
| Weight:                      | 510g (including batteries)   |
| Dimensions:                  | 170 x 135x 41 mm   |
| Measuring procedure:         | oscillometric, corresponding to Korotkoff method: Phase I systolic, Phase V diastolic                                    |
| Measurement range:           | 60 - 255 mmHg – systolic blood pressure<br>30 - 200 mmHg – diastolic blood pressure<br>40 - 200 beats per minute – pulse |
| Cuff pressure display range: | 0 - 299 mmHg   |
| Resolution:                  | 1 mmHg   |
| Static accuracy:             | pressure within $\pm 3$ mmHg   |
| Pulse accuracy:              | $\pm 5$ % of the readout value   |
| Voltage source:              | NiMH Battery pack, 4.8V 2400mAh<br>Mains adapter DC 7.5V, 1.5 mA   |
| Battery lifetime:            | approx. 1000 measurements (after the battery pack is fully charged)  |
| IP Class:                    | IP20   |
| Reference to standards:      | IEC 60601-1;<br>IEC 60601-1-2 (EMC)<br>DIN EN ISO 81060-1<br>IEC 80601-2-30<br>EN 1060-1 /-3                             |

## 12. EMC

### **Guidance and manufacture's declaration – electromagnetic emission**

The RBP-100 Blood Pressure Monitor and the RBP-100 USB Blood Pressure Monitor is intended for use in the electromagnetic environment specified below. The customer of the user of the RBP-100 Blood Pressure Monitor and the RBP-100 USB Blood Pressure Monitor should assure that it is used in such an environment.

# RBP-100



| Emission test   | Compliance | Electromagnetic environment – guidance  |
|---|------------|---|
| RF emissions<br>CISPR 11                                    | Group 1    | The RBP-100 Blood Pressure Monitor and the RBP-100 USB Blood Pressure Monitor RF energy only for its internal function. Therefore, its RF emissions are very low and are not likely to cause any interference in nearby electronic equipment.<br><br>The RBP-100 Blood Pressure Monitor and the RBP-100 USB Blood Pressure Monitor is suitable for use in all establishments, other than domestic and those directly connected to the public low-voltage power supply network that supplies buildings used for domestic purposes. |
| RF emission<br>CISPR 11                                     | Class B    |   |
| Harmonic emissions<br>IEC 61000-3-2                         | Pass       |   |
| Voltage fluctuations/<br>flicker emissions<br>IEC 61000-3-3 | Pass       |   |

| Guidance and manufacture's declaration – electromagnetic immunity   |                               |                               |  |
|---|-------------------------------|-------------------------------|--|
| The RBP-100 Blood Pressure Monitor and the RBP-100 USB Blood Pressure Monitor is intended for use in the electromagnetic environment specified below. The customer or the user of RBP-100 Blood Pressure Monitor and the RBP-100 USB Blood Pressure Monitor should assure that it is used in such an environment. |                               |                               |  |
| Immunity test   | IEC 60601 test level          | Compliance level              | Electromagnetic environment - guidance   |
| Electrostatic discharge (ESD)<br>IEC 61000-4-2  | Con:±8 kV<br>Air:±2,4,8,15 kV | Con:±8 kV<br>Air:±2,4,8,15 kV | Floors should be wood, concrete or ceramic tile. If floor are covered with synthetic material, the relative humidity should be at least 30%.   |
| Electrical fast transient/burst<br>IEC 61000-4-4  | Pass                          | Pass                          | Mains power quality should be that of a typical commercial or hospital environment.  |
| Surge<br>IEC 61000-4-5  | Pass                          | Pass                          | Mains power quality should be that of a typical commercial or hospital environment.  |
| Voltage dips, short interruptions and voltage variations on power supply input lines<br>IEC 61000-4-11  | Pass                          | Pass                          | Mains power quality should be that of a typical commercial or hospital environment. If the user of the RBP-100 Blood Pressure Monitor and the RBP-100 USB Blood Pressure Monitor requires continued operation during power mains interruptions, it is recommended that the RBP-100 Blood Pressure Monitor and the RBP-100 USB Blood Pressure Monitor be powered from an uninterruptible power supply or a battery. |
| Power frequency (50Hz/60Hz) magnetic field IEC 61000-4-8  | 30A/m                         | 30A/m                         | Power frequency magnetic fields should be at levels characteristic of a typical location in a typical commercial or hospital environment.  |
| NOTE U <sub>T</sub> is the a.c. mains voltage prior to application of the test level.   |                               |                               |  |

# RBP-100

| <b>Guidance and manufacture's declaration – electromagnetic immunity</b>  |                                    |                         |   |
|---|------------------------------------|-------------------------|---|
| The RBP-100 Blood Pressure Monitor and the RBP-100 USB Blood Pressure Monitor is intended for use in the electromagnetic environment specified below. The customer or the user of the RBP-100 Blood Pressure Monitor and the RBP-100 USB Blood Pressure Monitor should assure that it is used in such an environment.   |                                    |                         |   |
| <b>Immunity test</b>  | <b>IEC 60601 test level</b>        | <b>Compliance level</b> | <b>Electromagnetic environment - guidance</b>   |
| <p>Conducted RF<br/>IEC 61000-4-6</p>   | Pass                               | Pass                    | <p>Portable and mobile RF communications equipment should be used no closer to any part of the RBP-100 Blood Pressure Monitor and the RBP-100 USB Blood Pressure Monitor, including cables, than the recommended separation distance calculated from the equation applicable to the frequency of the transmitter.</p> <p><b>Recommended separation distance</b></p> $d = 1.2\sqrt{P}$ <p>d= 1.2√P 80 MHz to 800 MHz<br/>d= 2.3√P 800 MHz to 2.7 GHz</p>   |
| <p>Radiated RF<br/>IEC 61000-4-3</p> <p>Proximity fields from RF wireless communications equipment</p>  | <p>3 V/m<br/>80 MHz to 2.7 GHz</p> | 3 V/m                   | <p>Where <i>P</i> is the maximum output power rating of the transmitter in watts (W) according to the transmitter manufacturer and <i>d</i> is the recommended separation distance in metres (m). Field strengths from fixed RF transmitters, as determined by an electromagnetic site survey,<sup>a</sup> should be less than the compliance level in each frequency range.<sup>b</sup></p> <p>Interference may occur in the vicinity of equipment marked with the following symbol:</p>  |
| <p>NOTE 1 At 80 MHz and 800 MHz, the higher frequency range applies.</p> <p>NOTE 2 These guidelines may not apply in all situations. Electromagnetic propagation is affected by absorption and reflection from structures, objects and people.</p>  |                                    |                         |   |
| <p>a Field strengths from fixed transmitters, such as base stations for radio (cellular/cordless) telephones and landmobile radios, amateur radio, AM and FM radio broadcast and TV broadcast cannot be predicted theoretically with accuracy. To assess the electromagnetic environment due to fixed RF transmitters, an electromagnetic site survey should be considered. If the measured field strength in the location in which the RBP-100 Blood Pressure Monitor and the RBP-100 USB Blood Pressure Monitor is used exceeds the applicable RF compliance level above, the RBP-100 Blood Pressure Monitor and the RBP-100 USB Blood Pressure Monitor should be observed to verify normal operation. If abnormal performance is observed, additional measures may be necessary, such as re-orienting or relocating the RBP-100 Blood Pressure Monitor and the RBP-100 USB Blood Pressure Monitor.</p> <p>b Over the frequency range 150 kHz to 80 MHz, field strengths should be less than 3 V/m.</p> |                                    |                         |   |

# RBP-100



**Recommended separation distances between**

**portable and mobile RF communications equipment and the No touch Infrared Body Thermometer.**

The RBP-100 Blood Pressure Monitor and the RBP-100 USB Blood Pressure Monitor is intended for use in an electromagnetic environment in which radiated RF disturbances are controlled. The customer or the user of the RBP-100 Blood Pressure Monitor and the RBP-100 USB Blood Pressure Monitor can help prevent electromagnetic interference by maintaining a minimum distance between portable and mobile RF communications equipment (transmitters) and the RBP-100 Blood Pressure Monitor and the RBP-100 USB Blood Pressure Monitor as recommended below, according to the maximum output power of the communications equipment.

| Rated maximum output power of transmitter (W) | Separation distance according to frequency of transmitter (m) |  |   |
|---|---|--|---|
|   | 150 KHz to 80 MHz<br>$d = 1,2\sqrt{P}$                        | 80 MHz to 800 MHz<br>$d = 1,2\sqrt{P}$ | 800 MHz to 2.7 GHz<br>$d = 2,3\sqrt{P}$ |
| 0.01  | <b>0.12</b>   | <b>0.12</b>                            | <b>0.23</b>                             |
| 0.1   | <b>0.38</b>   | <b>0.38</b>                            | <b>0.73</b>                             |
| 1   | <b>1.2</b>  | <b>1.2</b>                             | <b>2.3</b>                              |
| 10  | <b>3.8</b>  | <b>3.8</b>                             | <b>7.3</b>                              |
| 100   | <b>12</b>   | <b>12</b>                              | <b>23</b>                               |

For transmitters rated at a maximum output power not listed above, the recommended separation distance d in metres (m) can be estimated using the equation applicable to the frequency of the transmitter, where P is the maximum output power rating of the transmitter in watts (W) according to the transmitter manufacturer.

NOTE 1 At 80 MHz and 800 MHz, the separation distance for the higher frequency range applies.

NOTE 2 These guidelines may not apply in all situations. Electromagnetic propagation is affected by absorption and reflection from structures, objects and people.

## 11. WARRANTY

### Limited Warranty

This product has been manufactured under the strictest quality standards and has undergone a thorough final quality check before leaving our factory.

We are therefore pleased to be able to provide a warranty of 2 years from the date of purchase on all defects, which can verifiably be shown to be due to material or manufacturing faults.

A warranty claim does not apply in the case of improper handling.

All defective parts of the product will be replaced or repaired free of charge within the warranty period. This does not apply to wearing parts.

Please remember that all warranty claims have to be made during the warranty period.

We will, of course, be pleased to carry out checks or repairs after expiry of the warranty period at a charge.

You are also welcome to request a provisional cost estimate from us free of charge.

In case of a warranty claim or repair, please return the Riester product with the completed description of the failure, serial number, purchasing information to the following address:



**Rudolf Riester GmbH**  
**Bruckstr. 31**  
**72417 Jungingen**  
**Germany**

# RBP-100

905160 Rev. 0 2018-12  
Änderungen vorbehalten • Subject to alterations • Sous réserve de modifications • Sujeto a modificaciones • Soggetto a modifiche



**Rudolf Riester GmbH** P.O. Box 35 | Bruckstraße 31 | 72417 Jungingen | Germany  
Tel. (+49) 7477-9270-0 | Fax. (+49) 7477-9270-70 | info@riester.de | www.riester.de